

- » Xtra power for use on cohesive materials & gradients.
- » Xtra strong, durable design.
- » Low Hand-Arm Vibration.
- » Triple-Filtration Air Cleaner System on Petrol models and Dual-Filtration on Diesel model.
- » Duel-Filtration Fuel System.
- » Swing-Out engine protection for easy access to maintenance points (60 & 68 only)
- » Carburettor Primer Bulb for easy start in any conditions (GX100 only)
- » Low-maintenance leg with Oil Level Sight Glass.
- » Lower Grab Handle and Front Roller for easy transportation. Both easily replaceable.
- » Wooden & Plastic Foot options, with various widths available.
- » Service Kits available.
- » Wheel Kit option available.
- » Customer colour options (60 & 68 only).

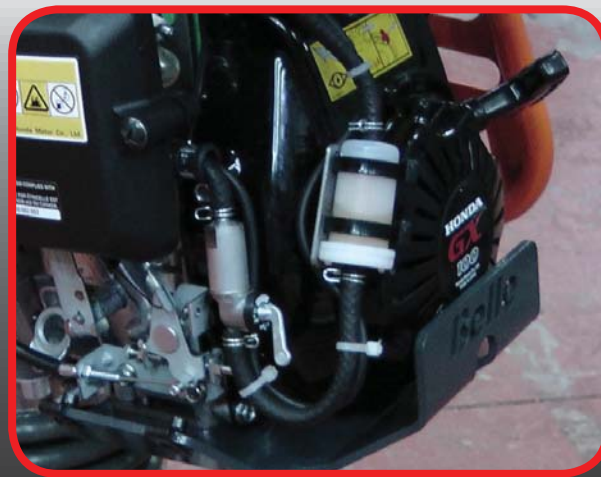

Duel Fuel Filtration System



Triple Filter Air Cleaner on Petrol models and Dual Filter on Diesel.



Carburettor Primer Bulb (GX100 only)



RTX RANGE

The **BRAND NEW**
Rammers from...
ALTRAD BELLE



Dealer Stamp:



RTX Range
Heavy Duty, Narrow Body
Trench Rammers

No.1 for Light Construction Equipment

ALTRAD... BELLE... BarOmix... FORT... Limex... Richard Fraise...



COMPACTING... MIXING... CONCRETING... CUTTING... BREAKING... MOVING... WHEELBARROWS

ALTRAD Belle Head Office, Sheen, Nr. Buxton, Derbyshire, SK17 0EU
Tel: (+44) 01298 84606 Fax: (+44) 01298 84722 Email: sales@belle-group.co.uk
www.ALTRAD-Belle.com

Belle Group reserve the right to amend or improve any specifications in this brochure without notice.



RTX
50

RTX50, Honda GX100, 4 Stroke Air Cooled

Code	RTX50
A - Width (mm)	345
B - Length (mm)	670
C - Height (mm)	975
D - Ramming Shoe Width (mm)	230
E - Ramming Shoe Length (mm)	335
Maximum Output (kW)	2.3
Fuel Type	Unleaded
Fuel Tank Capacity	2.5
Starting Mechanism	Recoil
Operational Weight (Kg)	57.7
Vibration Frequency (Hz)	11
Impact Force (kN)	12.5
Blows Per Minute (bpm)	450 - 660
Stroke (mm)	52
Noise Level (dB(A))	108

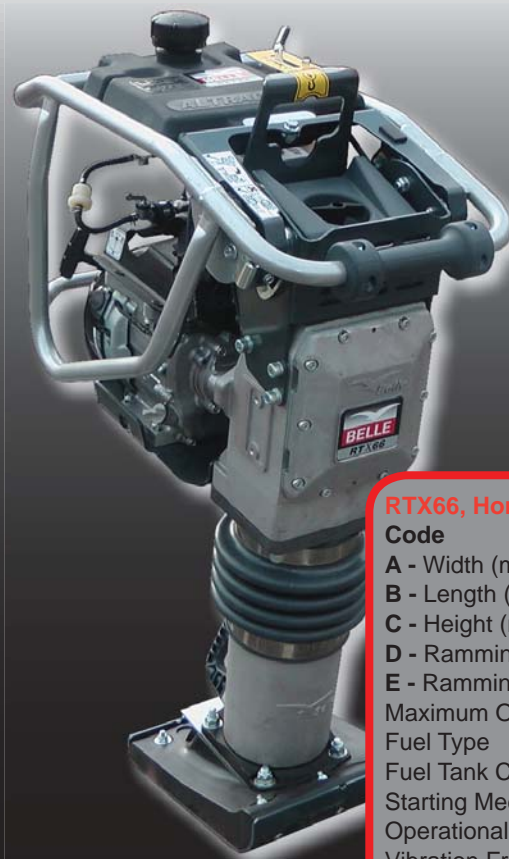

RTX
66

RTX66, Honda GX120, 4 Stroke Air Cooled

Code	RTX66
A - Width (mm)	425
B - Length (mm)	700
C - Height (mm)	1065
D - Ramming Shoe Width (mm)	280
E - Ramming Shoe Length (mm)	335
Maximum Output (kW)	2.6
Fuel Type	Unleaded
Fuel Tank Capacity	2.5
Starting Mechanism	Recoil
Operational Weight (Kg)	79
Vibration Frequency (Hz)	10
Impact Force (kN)	16.5
Blows Per Minute (bpm)	450 - 600
Stroke (mm)	52
Noise Level (dB(A))	108

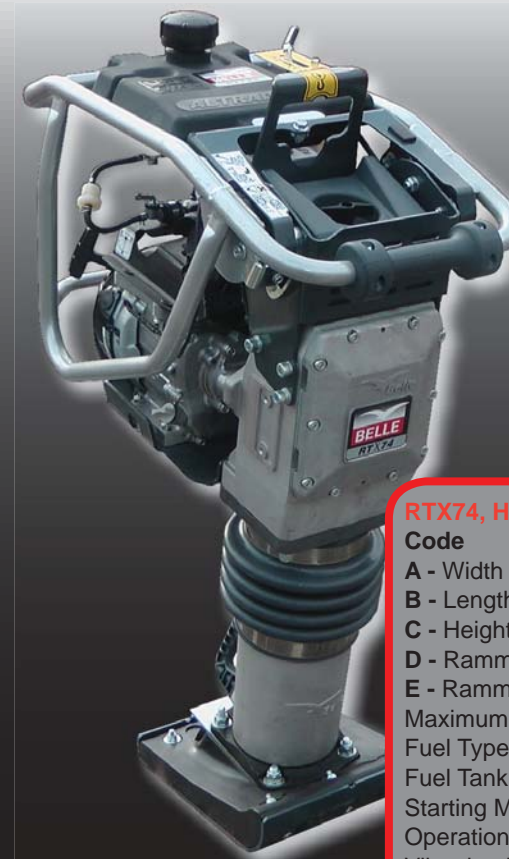

RTX
74

RTX74, Honda GX120, 4 Stroke Air Cooled

Code	RTX74
A - Width (mm)	425
B - Length (mm)	700
C - Height (mm)	1065
D - Ramming Shoe Width (mm)	280
E - Ramming Shoe Length (mm)	335
Maximum Output (kW)	2.6
Fuel Type	Unleaded
Fuel Tank Capacity	2.5
Starting Mechanism	Recoil
Operational Weight (Kg)	84
Vibration Frequency (Hz)	10
Impact Force (kN)	18.6
Blows Per Minute (bpm)	450 - 600
Stroke (mm)	52
Noise Level (dB(A))	108



RTX
60

RTX60, Honda GX100, 4 Stroke Air Cooled

Code	RTX60
A - Width (mm)	345
B - Length (mm)	705
C - Height (mm)	975
D - Ramming Shoe Width (mm)	165
E - Ramming Shoe Length (mm)	335
Maximum Output (kW)	2.3
Fuel Type	Unleaded
Fuel Tank Capacity	2.5
Starting Mechanism	Recoil
Operational Weight (Kg)	60
Vibration Frequency (Hz)	11
Impact Force (kN)	13.6
Blows Per Minute (bpm)	450 - 660
Stroke (mm)	52
Noise Level (dB(A))	108



RTX
68

RTX68, Honda GX100, 4 Stroke Air Cooled

Code	RTX68
A - Width (mm)	345
B - Length (mm)	705
C - Height (mm)	1040
D - Ramming Shoe Width (mm)	280
E - Ramming Shoe Length (mm)	335
Maximum Output (kW)	2.3
Fuel Type	Unleaded
Fuel Tank Capacity	2.5
Starting Mechanism	Recoil
Operational Weight (Kg)	70
Vibration Frequency (Hz)	11
Impact Force (kN)	16
Blows Per Minute (bpm)	450 - 660
Stroke (mm)	52
Noise Level (dB(A))	108

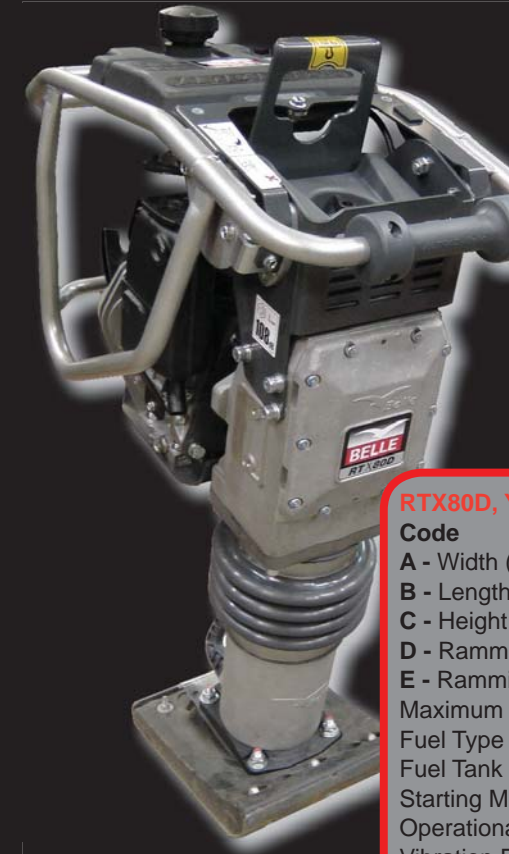

RTX
80D

RTX80D, Yanmar L48, Single Cylinder

Code	RTX80D
A - Width (mm)	425
B - Length (mm)	700
C - Height (mm)	1081
D - Ramming Shoe Width (mm)	280
E - Ramming Shoe Length (mm)	335
Maximum Output (kW)	3.5
Fuel Type	Diesel
Fuel Tank Capacity	2.5
Starting Mechanism	Recoil
Operational Weight (Kg)	86
Vibration Frequency (Hz)	10
Impact Force (kN)	20.5
Blows Per Minute (bpm)	450 - 600
Stroke (mm)	52
Noise Level (dB(A))	108